

FASTEN ASS3EMBLY TO A 6mm STEEL PLATE BY FOUR M 10 X 30mm LG HEX HD BOLTS, NUTS AND LOCK WASHERS.

ROUNDS AND FILLETS R3

FIT	BETWEEN PARTS
H8/f7	4 AND 5
H7/p6	3 AND 5
H8/f7	2 AND 4

PARTS LIST			
ITEM	QTY	PART NUMBER	MATERIAL
1	1	TOP PLATE	MALLEABLE IRON
2	1	WHEEL	MALLEABLE IRON
3	2	AXLE SUPPORT	MALLEABLE IRON
4	1	AXLE	SAE 1020
5	2	BUSHING	BRONZE

LEGEND

∅ DIAMETER

R RADIUS

° DEGREES

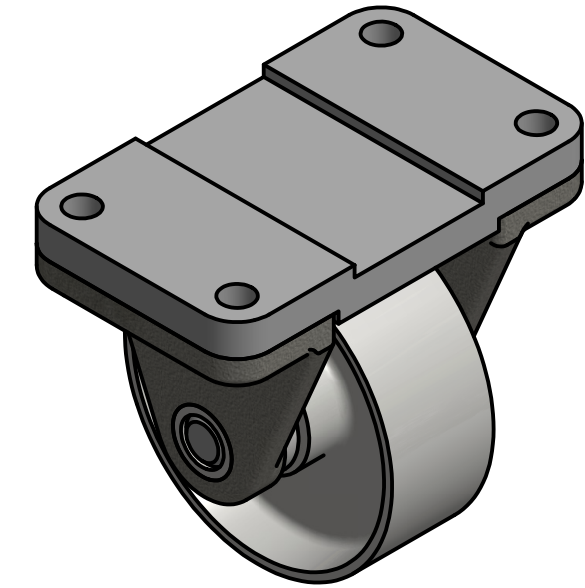
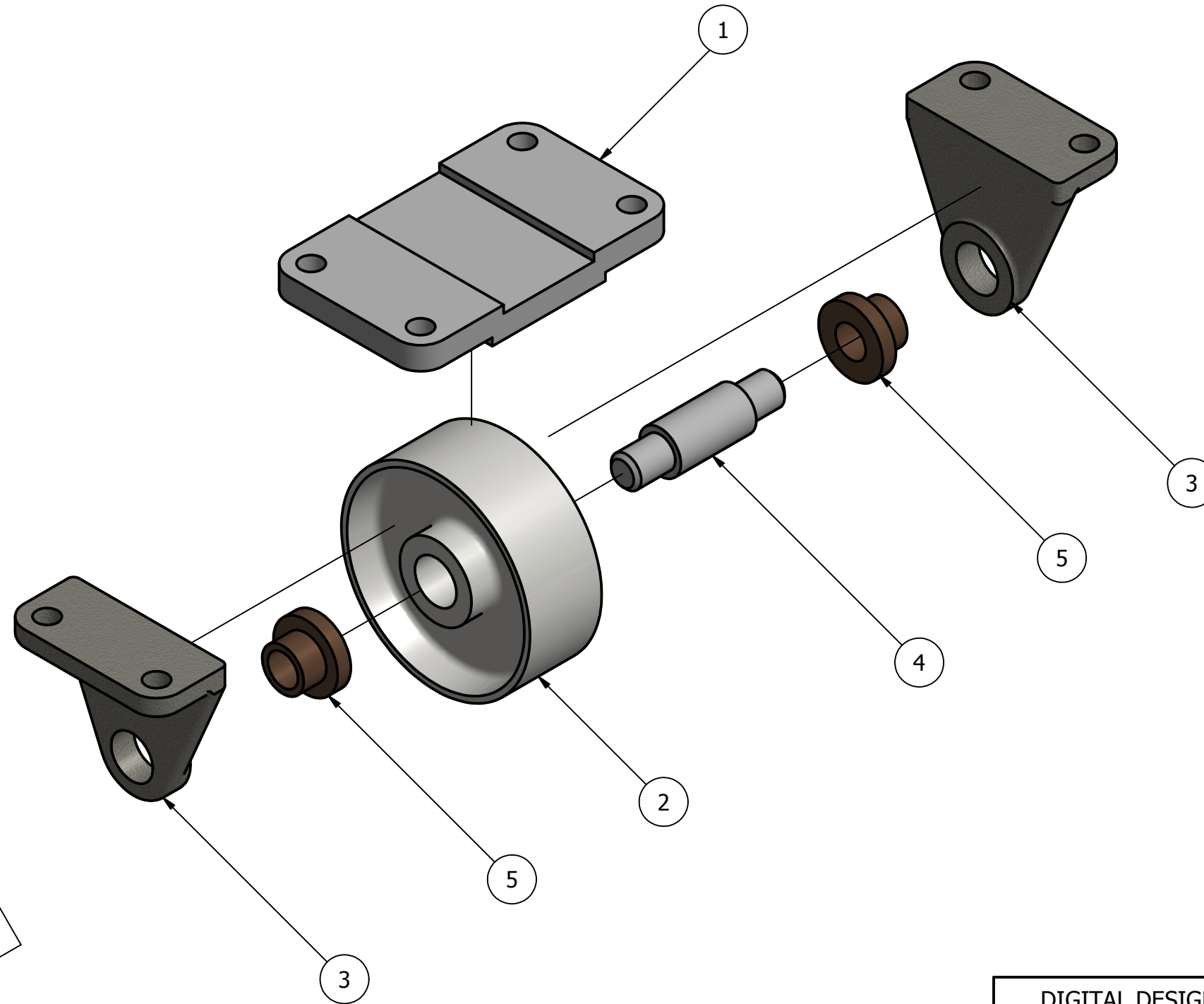

CASTER ASSEMBLY
SCALE 1 / 2

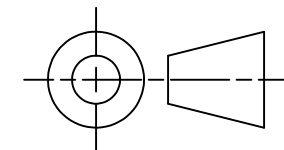

METRIC

DIGITAL DESIGN GRAPHICS TECHNOLOGY	NAME: ISRAEL VALENCIA	DWG NAME: 9-51 CASTER	SHEET NO: 1 OF 2
	COURSE: DDGT 120	SCALE: AS NOTED	
	DATE: 11/8/2012		

PRODUCED BY AN AUTODESK EDUCATIONAL PRODUCT

PRODUCED BY AN AUTODESK EDUCATIONAL PRODUCT

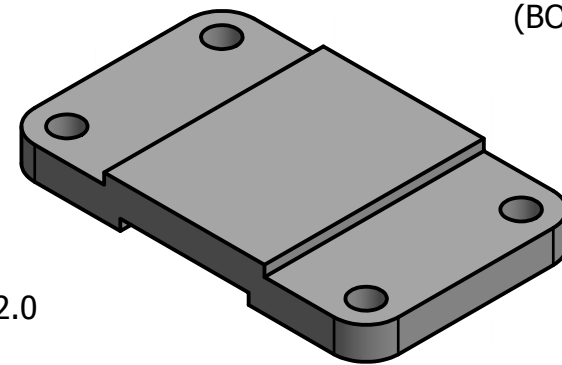
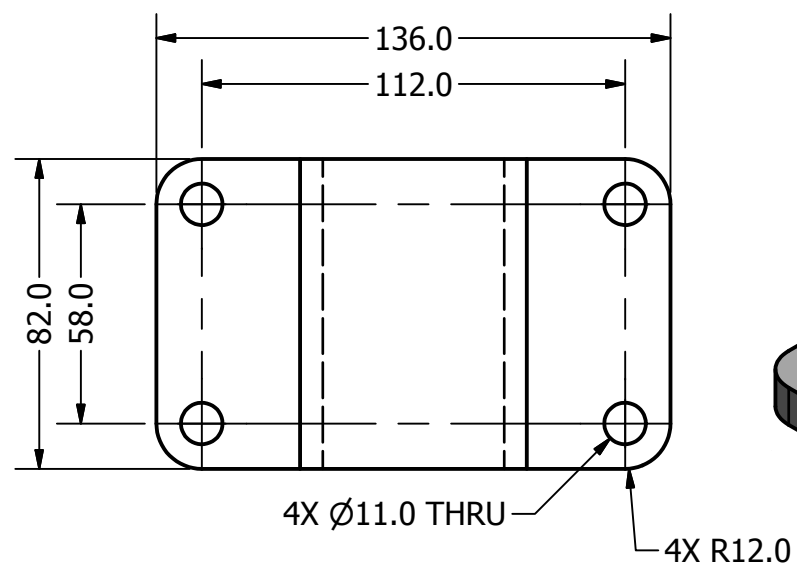

2.0 X 45.0° CHAMFER
(BOTH SIDES)

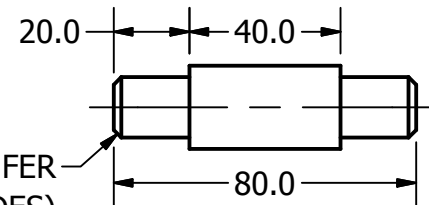

AXLE
SCALE 1 / 2

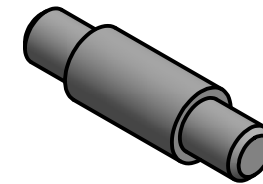
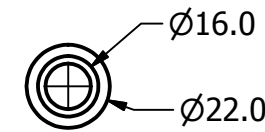

PARTS LIST		
ITEM	QTY	PART NUMBER
1	1	TOP PLATE
2	1	WHEEL
4	1	AXLE
3	2	AXLE SUPPORT
5	2	BUSHING

ROUNDS AND FILLETS R 3

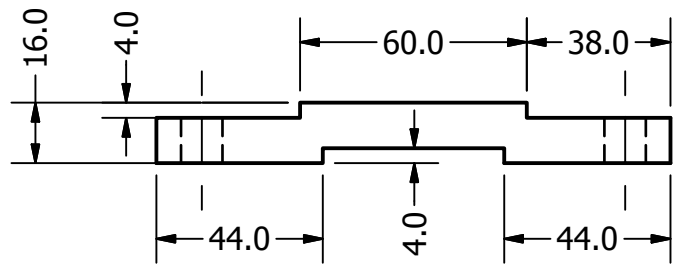

TOP PLATE
SCALE 1 / 2

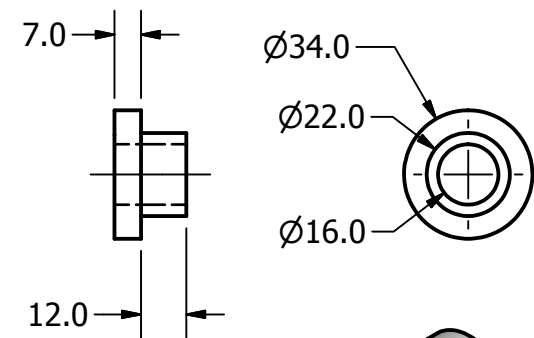

BUSHING
SCALE 1 / 2

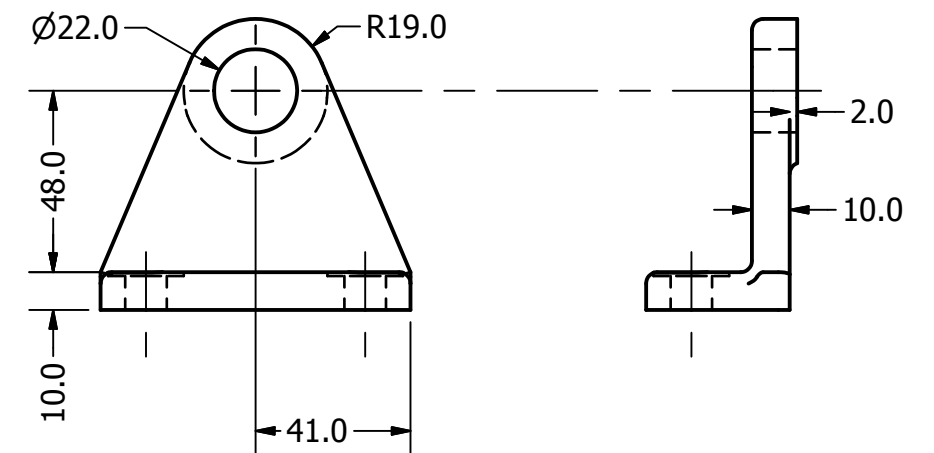
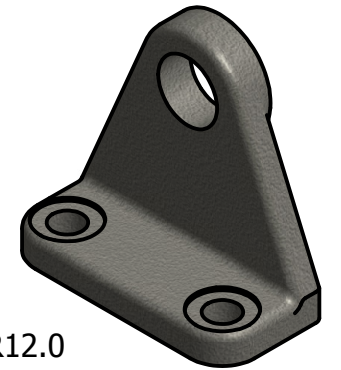
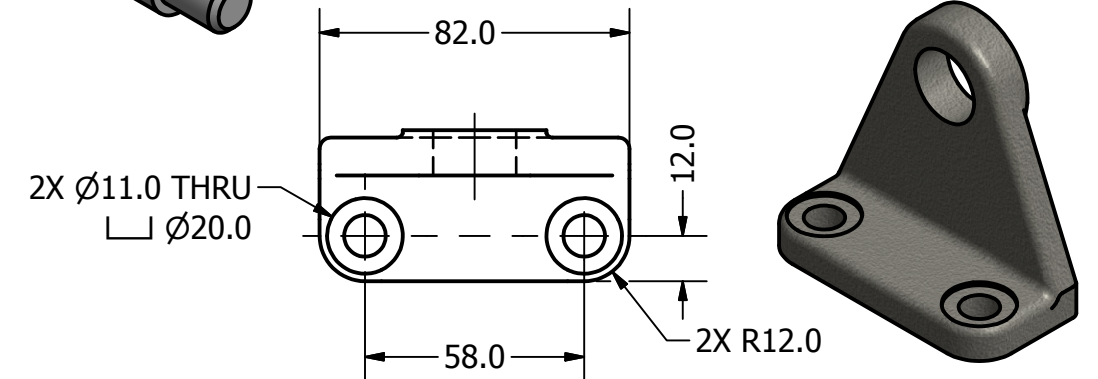
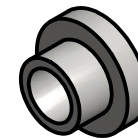

AXLE SUPPORT
SCALE 1 / 2

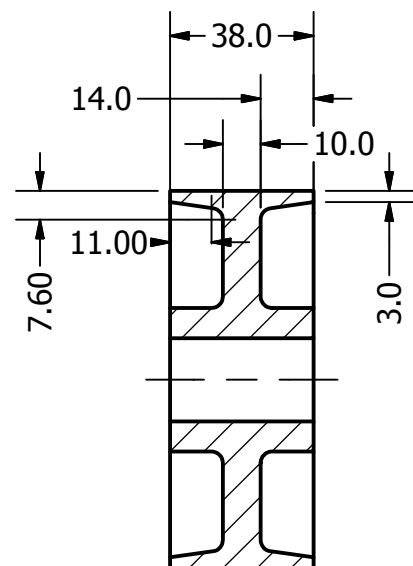
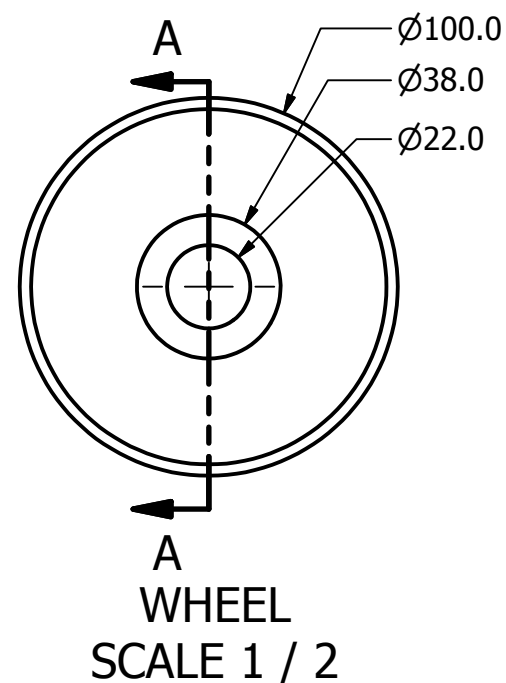

SECTION A-A
SCALE 1 / 2

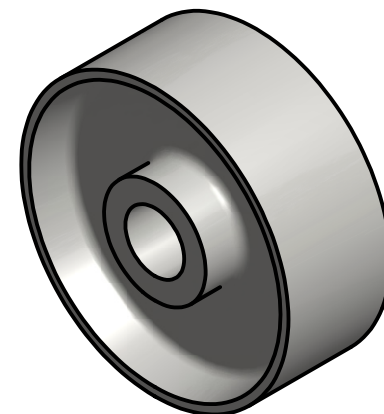

DIGITAL DESIGN GRAPHICS TECHNOLOGY	NAME: ISRAEL VALENCIA	DWG NAME: 9-51 CASTER	SHEET NO: 2 OF 2
	COURSE: DDGT 120	SCALE: AS NOTED	
	DATE: 11/8/2012		